

ALL-TERRAIN ATF 400G-6

*Vorläufig
Preliminary*

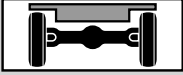



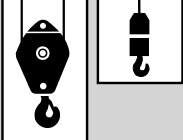

Lift + Release
Adjuster

| | | | | | | | | |
|--|---------------------|----|----|----|----|----|----|-------------------------------------|
|  | Achse / Axle | 1 | 2 | 3 | 4 | 5 | 6 | Gesamtgewicht / Total weight |
| | (t) | 12 | 12 | 12 | 12 | 12 | 12 | 72 |



|  | Traglast / Lifting capacity / Force de levage / Capacidad de elevación | Rollen / Sheaves Pulies / Poleas | Stränge / Parts of line Brins / Ramales de cable | Gewicht / Weight Poid / Peso |
|--|---|---|---|-------------------------------------|
| | 250 t* | 9 | 19 | 1800 kg |
| | 200 t* | 7 | 15 | 1600 kg |
| | 160 t* | 5 | 11 | 1400 kg |
| | 100 t* | 3 | 7 | 1300 kg |
| | 40 t | 1 | 3 | 600 kg/800 kg |
| | 12.5 t | - | 1 | 410 kg |

* Doppelhaken
* Rams horn
* Moufle avec crochet marin
* Gancho doble

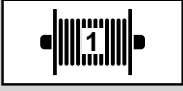

|  | 1 | 2 | 3 | 4 | 5 | 6 | 7 | 8 | 9 | 10 | 11 | 12 | R1 | R2 |  |
|---|-----|-----|-----|------|------|------|------|------|------|------|------|------|-----|-----|---|
| 385/95 (14.00) km/h  | 3.6 | 4.6 | 5.9 | 7.6 | 9.6 | 12.3 | 16.3 | 20.9 | 27.0 | 34.6 | 43.9 | 56.3 | 3.9 | 4.9 | 60.0%* |
| | 5.5 | 7.0 | 9.1 | 11.7 | 14.8 | 19.0 | 25.1 | 32.1 | 41.6 | 53.3 | 67.5 | 85.0 | 5.9 | 7.6 | 60.0% |
| 445/95 (16.00) km/h  | 3.9 | 5.0 | 6.4 | 8.3 | 10.5 | 13.4 | 17.7 | 22.7 | 29.4 | 37.7 | 47.7 | 61.2 | 4.2 | 5.4 | 53.5%* |
| | 6.0 | 7.7 | 9.9 | 12.7 | 16.1 | 20.6 | 27.3 | 35.0 | 45.2 | 58.0 | 73.5 | 85.0 | 6.5 | 8.3 | 53.5% |

* Mit Geländeübersetzung
* Off road range

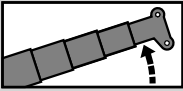
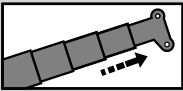
| V+  | Stufenlos Infinitely variable | Seil Rope | Max. Seilzug Max. single line pull |
|---|--|------------------|---|
|  | 0 - 125 m/min für einfachen Strang single line | 23 mm / 350 m | 120 kN |
|  | 0 - 125 m/min für einfachen Strang single line | 23 mm / 580 m | 120 kN |
|  | 0 - 1.1 min ⁻¹ | | |
|  | - 0.8° - +83.5° ca. 50 s approx. 50 s | | |
|  | 15.0 m - 60.0 m ca. 500 s approx. 500 s | | |

Hubhöhen
Lifting heights



DIN/ISO/EN

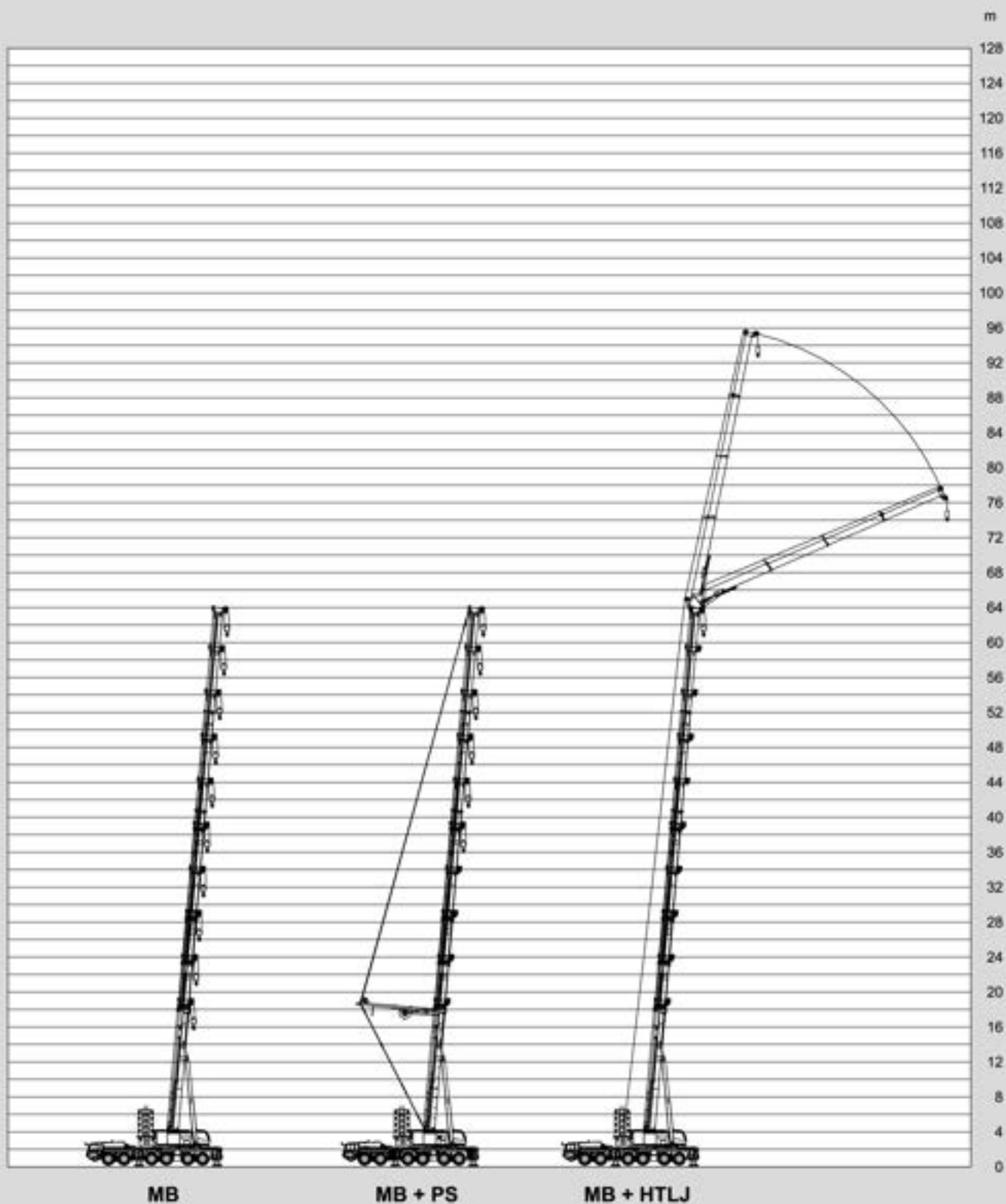

Hubhöhen
Lifting heights

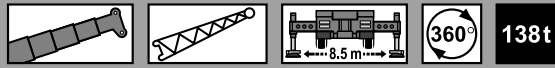

DIN / ISO / EN

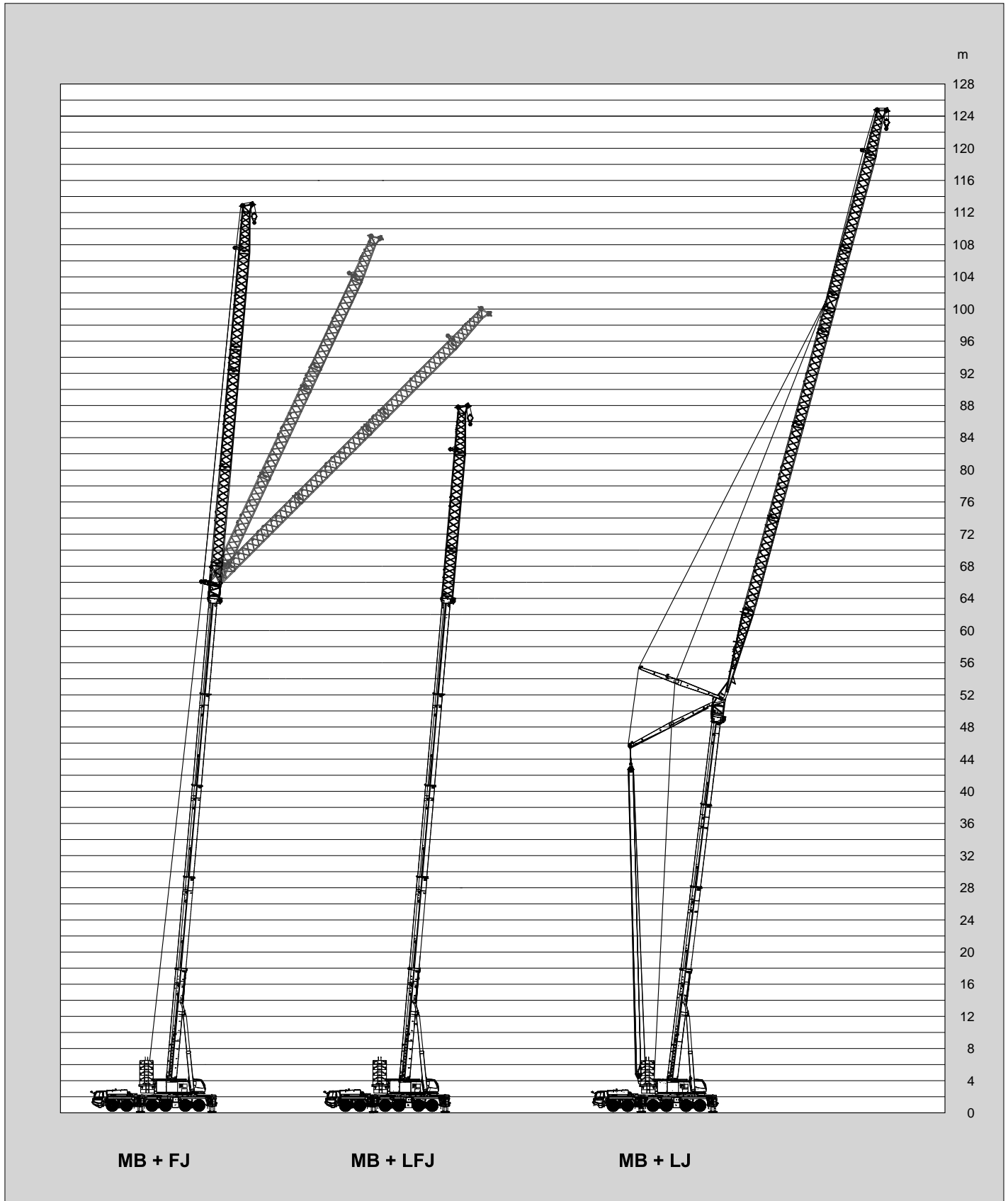

Tragfähigkeiten Lifting capacities

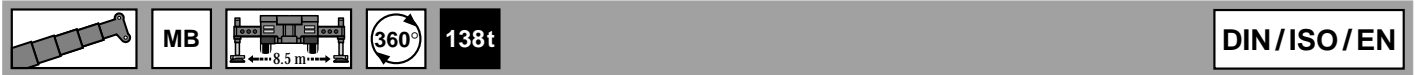

|  R → m | 15.0 m* | 15.0 m | 20.0 m | 25.1 m | 30.2 m | 35.2 m | 40.3 m | 45.4 m | 50.4 m | 55.5 m | 60.0 m |
|---|----------|---------|--------|--------|--------|--------|--------|--------|--------|--------|--------|
| 2.7 | 400.0*** | | | | | | | | | | |
| 3.0 | 360.0** | | | | | | | | | | |
| 4.0 | 264.6** | 245.6** | 170.0 | 162.0 | 139.0 | | | | | | |
| 5.0 | 200.55** | 184.8** | 170.0 | 162.0 | 139.0 | 123.4 | | | | | |
| 6.0 | | 164.0 | 163.8 | 162.0 | 139.0 | 113.9 | 84.2 | | | | |
| 7.0 | | 147.3 | 147.0 | 146.5 | 128.0 | 103.2 | 84.2 | 71.6 | | | |
| 8.0 | | 133.1 | 132.8 | 132.2 | 118.2 | 94.3 | 84.2 | 71.6 | 54.3 | | |
| 9.0 | | 120.4 | 120.1 | 119.5 | 109.9 | 86.7 | 79.5 | 69.6 | 54.3 | 45.0 | |
| 10.0 | | 109.7 | 109.4 | 108.8 | 102.7 | 81.2 | 73.7 | 65.8 | 54.3 | 45.0 | 38.0 |
| 12.0 | | 84.4 | 92.4 | 92.3 | 90.8 | 72.4 | 64.0 | 59.4 | 51.0 | 44.6 | 38.0 |
| 14.0 | | | 79.6 | 79.4 | 79.6 | 65.4 | 56.6 | 52.8 | 45.7 | 40.4 | 38.0 |
| 16.0 | | | 65.4 | 69.4 | 69.5 | 59.6 | 50.6 | 47.2 | 41.3 | 36.9 | 35.1 |
| 18.0 | | | 39.2 | 61.2 | 61.3 | 54.8 | 45.7 | 42.6 | 37.7 | 34.0 | 32.3 |
| 20.0 | | | | 53.2 | 54.5 | 50.8 | 41.6 | 38.8 | 34.6 | 31.4 | 29.5 |
| 22.0 | | | | 39.9 | 48.9 | 47.4 | 38.2 | 35.6 | 32.0 | 29.0 | 27.1 |
| 24.0 | | | | | 43.2 | 44.5 | 35.2 | 32.8 | 29.8 | 26.9 | 25.0 |
| 26.0 | | | | | 36.5 | 40.9 | 32.7 | 30.4 | 27.8 | 25.1 | 23.2 |
| 28.0 | | | | | 22.4 | 36.9 | 30.5 | 28.3 | 26.0 | 23.5 | 21.6 |
| 30.0 | | | | | | 31.3 | 28.4 | 26.5 | 24.5 | 22.1 | 20.2 |
| 32.0 | | | | | | 23.5 | 26.3 | 24.8 | 23.1 | 20.8 | 19.0 |
| 34.0 | | | | | | | 24.6 | 23.6 | 21.9 | 19.7 | 17.8 |
| 36.0 | | | | | | | 21.6 | 22.3 | 20.8 | 18.7 | 16.7 |
| 38.0 | | | | | | | 15.0 | 21.0 | 19.7 | 17.7 | 15.5 |
| 40.0 | | | | | | | | 19.7 | 18.5 | 16.9 | 14.5 |
| 42.0 | | | | | | | | 15.1 | 17.4 | 16.1 | 13.6 |
| 44.0 | | | | | | | | | 16.3 | 15.4 | 12.7 |
| 46.0 | | | | | | | | | 15.0 | 14.8 | 11.9 |
| 48.0 | | | | | | | | | 10.2 | 14.1 | 11.2 |
| 50.0 | | | | | | | | | | 13.3 | 10.6 |
| 52.0 | | | | | | | | | | 10.8 | 10.0 |
| 54.0 | | | | | | | | | | | 9.4 |
| 56.0 | | | | | | | | | | | 8.9 |
| 58.0 | | | | | | | | | | | 4.8 |

*) Nach hinten / Over rear

**) Mit Schwerlasteinrichtung 1, Zentralabstützung und Zusatzrollen / With heavy duty attachment 1, center support and additional sheaves

***) Mit Schwerlasteinrichtung 2, Zentralabstützung und Zusatzrollen / With heavy duty attachment 2, center support and additional sheaves

Tragfähigkeiten
Lifting capacities

| | | | | | | | | | | |
|--|-----------|---|---|-------------|-------------------|--|--|--|--|--|
|  | MB |  |  | 118t | DIN/ISO/EN | | | | | |
|--|-----------|---|---|-------------|-------------------|--|--|--|--|--|

|  R m | 15.0 m | 20.0 m | 25.1 m | 30.2 m | 35.2 m | 40.3 m | 45.4 m | 50.4 m | 55.5 m | 60.0 m |
|---|--------|--------|--------|--------|--------|--------|--------|--------|--------|--------|
| 3.0 | 242.9 | 170.0 | 162.0 | | | | | | | |
| 4.0 | 208.8 | 170.0 | 162.0 | 139.0 | | | | | | |
| 5.0 | 182.7 | 170.0 | 162.0 | 139.0 | 123.4 | | | | | |
| 6.0 | 160.5 | 160.1 | 159.4 | 139.0 | 113.9 | 84.2 | | | | |
| 7.0 | 141.0 | 140.6 | 139.9 | 128.0 | 103.2 | 84.2 | 71.6 | | | |
| 8.0 | 125.3 | 124.9 | 124.2 | 118.2 | 94.3 | 84.2 | 71.6 | 54.3 | | |
| 9.0 | 112.4 | 112.0 | 111.9 | 109.9 | 86.7 | 79.5 | 69.6 | 54.3 | 45.0 | |
| 10.0 | 101.7 | 101.3 | 101.2 | 101.4 | 81.2 | 73.7 | 65.8 | 54.3 | 45.0 | 38.0 |
| 12.0 | 78.3 | 84.5 | 84.4 | 84.6 | 72.4 | 64.0 | 59.4 | 51.0 | 44.6 | 38.0 |
| 14.0 | | 72.0 | 72.8 | 72.0 | 65.4 | 56.6 | 52.8 | 45.7 | 40.4 | 38.0 |
| 16.0 | | 60.7 | 63.1 | 62.3 | 59.6 | 50.6 | 47.2 | 41.3 | 36.9 | 34.3 |
| 18.0 | | 36.2 | 55.5 | 54.7 | 54.8 | 45.7 | 42.6 | 37.7 | 34.0 | 31.0 |
| 20.0 | | | 49.3 | 48.4 | 49.4 | 41.6 | 38.8 | 34.6 | 31.4 | 28.3 |
| 22.0 | | | 37.9 | 43.3 | 44.3 | 38.2 | 35.6 | 32.0 | 29.0 | 26.0 |
| 24.0 | | | | 40.3 | 39.3 | 35.2 | 32.8 | 29.8 | 26.9 | 24.0 |
| 26.0 | | | | 33.7 | 35.0 | 32.7 | 30.4 | 27.8 | 25.1 | 22.2 |
| 28.0 | | | | 20.5 | 31.5 | 30.5 | 28.3 | 26.0 | 23.5 | 20.7 |
| 30.0 | | | | | 28.5 | 27.7 | 26.5 | 24.5 | 22.1 | 19.3 |
| 32.0 | | | | | 21.6 | 25.1 | 24.8 | 23.1 | 20.8 | 18.1 |
| 34.0 | | | | | | 22.9 | 23.6 | 21.9 | 19.7 | 17.1 |
| 36.0 | | | | | | 19.7 | 21.6 | 20.8 | 18.7 | 16.0 |
| 38.0 | | | | | | 14.3 | 19.9 | 19.7 | 17.7 | 14.9 |
| 40.0 | | | | | | | 18.4 | 18.3 | 16.9 | 13.9 |
| 42.0 | | | | | | | 13.7 | 16.9 | 16.1 | 13.0 |
| 44.0 | | | | | | | | 15.7 | 15.4 | 12.2 |
| 46.0 | | | | | | | | 13.7 | 14.8 | 11.4 |
| 48.0 | | | | | | | | 9.2 | 13.8 | 10.8 |
| 50.0 | | | | | | | | | 12.9 | 10.1 |
| 52.0 | | | | | | | | | 9.7 | 9.6 |
| 54.0 | | | | | | | | | | 9.0 |
| 56.0 | | | | | | | | | | 8.5 |
| 58.0 | | | | | | | | | | 4.8 |

Tragfähigkeiten
Lifting capacities







DIN/ISO/EN

|  m | 15.0 m | 20.0 m | 25.1 m | 30.2 m | 35.2 m | 40.3 m | 45.4 m | 50.4 m | 55.5 m | 60.0 m |
|--|--------|--------|--------|--------|--------|--------|--------|--------|--------|--------|
| R | | | | | | | | | | |
| 3.0 | 220.6 | 170.0 | 162.0 | | | | | | | |
| 4.0 | 179.1 | 170.0 | 162.0 | 139.0 | | | | | | |
| 5.0 | 148.9 | 148.5 | 147.8 | 137.1 | 123.0 | | | | | |
| 6.0 | 126.3 | 125.9 | 117.2 | 105.7 | 99.3 | 84.2 | | | | |
| 7.0 | 104.5 | 99.8 | 93.4 | 88.7 | 81.3 | 74.9 | 70.9 | | | |
| 8.0 | 77.9 | 80.0 | 79.4 | 74.1 | 68.2 | 62.8 | 60.5 | 54.3 | | |
| 9.0 | 61.4 | 63.3 | 64.1 | 62.8 | 57.8 | 53.4 | 51.8 | 49.2 | 45.0 | |
| 10.0 | 50.1 | 51.8 | 52.6 | 52.4 | 49.8 | 46.1 | 47.3 | 44.6 | 41.6 | 34.5 |
| 12.0 | 35.8 | 37.3 | 38.2 | 39.2 | 36.7 | 39.5 | 37.4 | 35.3 | 32.9 | 31.9 |
| 14.0 | | 28.5 | 29.3 | 39.1 | 30.1 | 30.4 | 29.9 | 28.7 | 26.8 | 26.0 |
| 16.0 | | 22.6 | 23.3 | 24.0 | 24.0 | 24.3 | 23.8 | 23.4 | 22.1 | 21.6 |
| 18.0 | | 18.5 | 19.0 | 19.7 | 19.6 | 19.8 | 19.4 | 19.0 | 18.3 | 18.1 |
| 20.0 | | | 15.8 | 16.4 | 16.3 | 16.5 | 16.1 | 15.6 | 15.0 | 15.1 |
| 22.0 | | | 13.4 | 13.9 | 13.8 | 13.9 | 13.5 | 13.1 | 12.4 | 12.6 |
| 24.0 | | | | 11.9 | 11.7 | 11.9 | 11.4 | 11.0 | 10.3 | 10.5 |
| 26.0 | | | | 10.3 | 10.1 | 10.2 | 9.7 | 9.3 | 8.6 | 8.8 |
| 28.0 | | | | 9.1 | 8.7 | 8.8 | 8.3 | 7.9 | 7.2 | 7.4 |
| 30.0 | | | | | 7.6 | 7.6 | 7.1 | 6.7 | 6.1 | 6.2 |
| 32.0 | | | | | 6.7 | 6.6 | 6.1 | 5.7 | 5.0 | 5.2 |
| 34.0 | | | | | | 5.7 | 5.2 | 4.8 | 4.2 | 4.3 |
| 36.0 | | | | | | 5.0 | 4.5 | 4.0 | 3.4 | 3.5 |
| 38.0 | | | | | | 4.5 | 3.8 | 3.4 | 2.7 | 2.8 |
| 40.0 | | | | | | | 3.3 | 2.8 | 2.1 | 2.2 |
| 42.0 | | | | | | | 2.8 | 2.3 | 1.6 | 1.6 |
| 44.0 | | | | | | | | 1.8 | | |
| 46.0 | | | | | | | | 1.4 | | |
| 48.0 | | | | | | | | 1.1 | | |





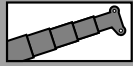

DIN/ISO/EN

|  m | 15.0 m | 20.0 m | 25.1 m | 30.2 m | 35.2 m | 40.3 m | 45.4 m | 50.4 m | 55.5 m | 60.0 m |
|--|--------|--------|--------|--------|--------|--------|--------|--------|--------|--------|
| R | | | | | | | | | | |
| 3.0 | 206.9 | 170.0 | 162.0 | | | | | | | |
| 4.0 | 165.8 | 165.5 | 162.0 | 139.0 | | | | | | |
| 5.0 | 126.0 | 108.4 | 99.2 | 86.8 | 74.8 | | | | | |
| 6.0 | 84.4 | 78.7 | 71.1 | 66.0 | 59.8 | 55.0 | | | | |
| 7.0 | 55.8 | 58.3 | 54.7 | 51.5 | 47.4 | 44.1 | 40.3 | | | |
| 8.0 | 40.5 | 42.7 | 43.7 | 41.7 | 38.8 | 36.5 | 33.5 | 30.7 | | |
| 9.0 | 31.0 | 33.0 | 34.2 | 34.7 | 32.5 | 30.8 | 28.2 | 25.7 | 22.9 | |
| 10.0 | 24.5 | 26.4 | 27.5 | 28.5 | 27.5 | 26.0 | 23.7 | 21.6 | 19.2 | 18.4 |
| 12.0 | 16.4 | 17.9 | 18.9 | 19.8 | 19.8 | 19.0 | 17.4 | 15.8 | 13.9 | 13.3 |
| 14.0 | | 12.9 | 13.7 | 14.6 | 14.5 | 14.4 | 13.1 | 11.8 | 10.2 | 9.8 |
| 16.0 | | 9.5 | 10.2 | 11.0 | 10.9 | 11.1 | 10.0 | 8.9 | 7.4 | 7.2 |
| 18.0 | | 7.3 | 7.8 | 8.5 | 8.4 | 8.6 | 7.7 | 6.7 | 5.4 | 5.2 |
| 20.0 | | | 6.0 | 6.6 | 6.5 | 6.7 | 5.9 | 5.0 | | |
| 22.0 | | | 4.5 | 5.0 | 4.9 | 5.1 | 4.4 | | | |
| 24.0 | | | | 3.8 | | 3.7 | 3.2 | | | |
| 26.0 | | | | 2.8 | | 2.6 | | | | |
| 28.0 | | | | 2.1 | | | | | | |

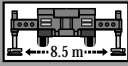

MB



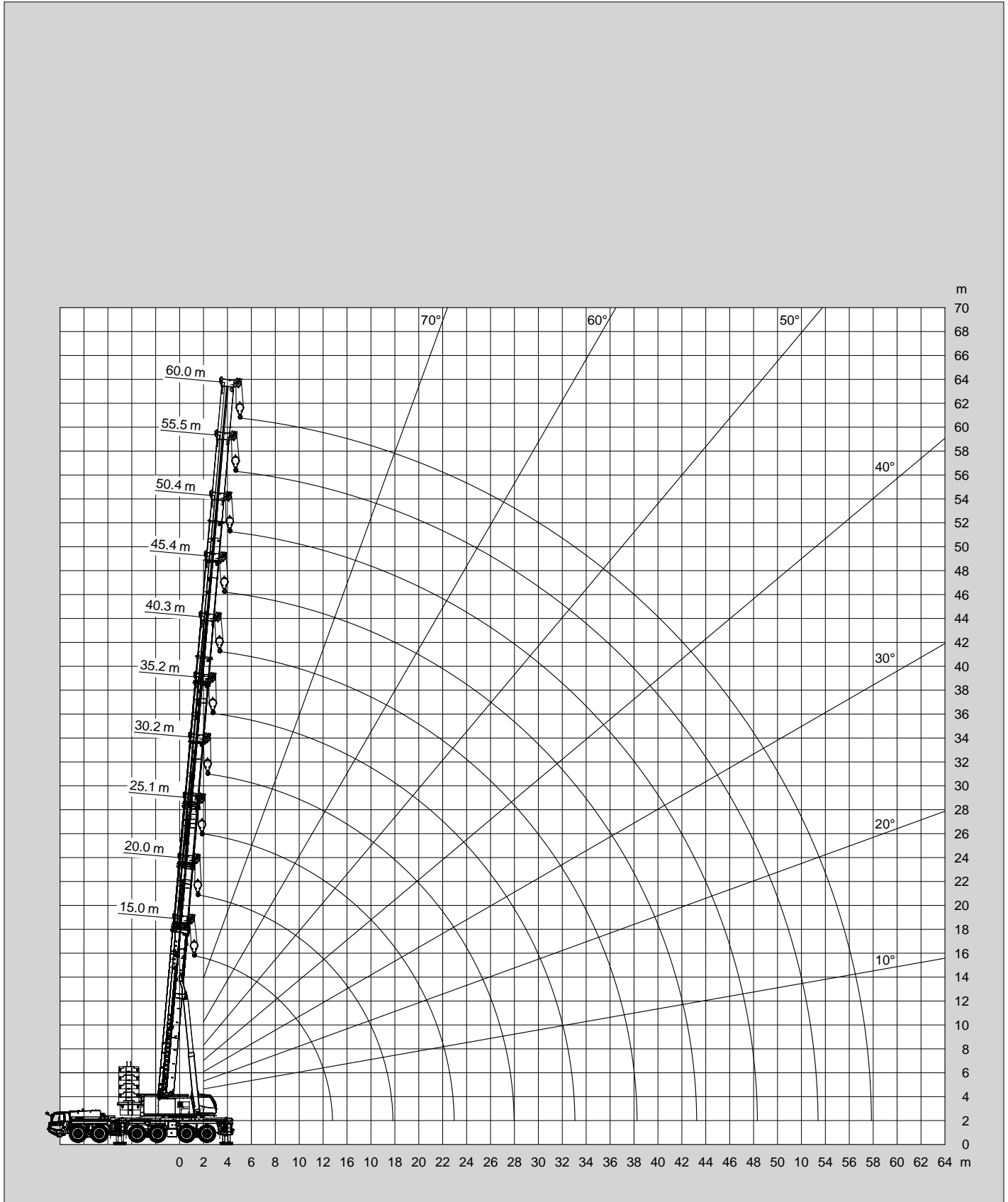

138t

DIN/ISO/EN

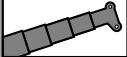

Tragfähigkeiten
Lifting capacities

| | | | | | |
|--|----------------|---|---|-------------|-------------------|
|  | MB + PS |  |  | 138t | DIN/ISO/EN |
|--|----------------|---|---|-------------|-------------------|

|  m | 35.3 m | 40.4 m | 45.4 m | 50.5 m | 55.6 m | 60.0 m |
|--|--------|--------|--------|--------|--------|--------|
| 4.0 | 118.0 | | | | | |
| 5.0 | 118.0 | | | | | |
| 6.0 | 118.0 | 84.2 | | | | |
| 7.0 | 112.6 | 84.2 | 68.0 | | | |
| 8.0 | 101.4 | 84.2 | 68.0 | 58.0 | | |
| 9.0 | 93.8 | 84.2 | 68.0 | 58.0 | 45.0 | |
| 10.0 | 86.3 | 82.4 | 68.0 | 58.0 | 45.0 | 34.9 |
| 12.0 | 74.6 | 71.2 | 68.0 | 58.0 | 44.8 | 34.6 |
| 14.0 | 65.3 | 62.8 | 59.9 | 58.0 | 44.4 | 34.2 |
| 16.0 | 58.1 | 55.6 | 53.7 | 51.6 | 44.0 | 33.8 |
| 18.0 | 52.4 | 50.3 | 48.0 | 46.8 | 43.7 | 33.4 |
| 20.0 | 47.6 | 45.6 | 43.9 | 42.5 | 41.3 | 33.0 |
| 22.0 | 43.5 | 41.6 | 40.0 | 39.0 | 37.7 | 32.7 |
| 24.0 | 40.0 | 38.4 | 36.9 | 35.8 | 34.8 | 32.4 |
| 26.0 | 37.0 | 35.5 | 34.1 | 33.2 | 32.3 | 31.3 |
| 28.0 | 32.5 | 33.0 | 31.6 | 30.8 | 30.0 | 29.1 |
| 30.0 | 26.5 | 30.8 | 29.5 | 28.9 | 28.1 | 27.1 |
| 32.0 | 18.7 | 27.8 | 27.6 | 27.1 | 26.3 | 25.5 |
| 34.0 | | 23.7 | 25.9 | 25.4 | 24.8 | 23.8 |
| 36.0 | | 18.4 | 23.6 | 24.0 | 23.4 | 22.6 |
| 38.0 | | 9.8 | 20.9 | 22.3 | 22.1 | 21.3 |
| 40.0 | | | 17.0 | 20.5 | 21.0 | 20.3 |
| 42.0 | | | 11.8 | 18.9 | 19.6 | 19.2 |
| 44.0 | | | | 16.1 | 18.1 | 18.1 |
| 46.0 | | | | 12.5 | 16.7 | 16.8 |
| 48.0 | | | | 6.8 | 15.0 | 15.5 |
| 50.0 | | | | | 12.2 | 14.4 |
| 52.0 | | | | | 8.6 | 12.8 |
| 54.0 | | | | | | 10.5 |
| 56.0 | | | | | | 7.4 |
| 58.0 | | | | | | 1.8 |

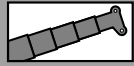

MB + PS

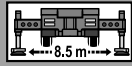

138t

DIN/ISO/EN

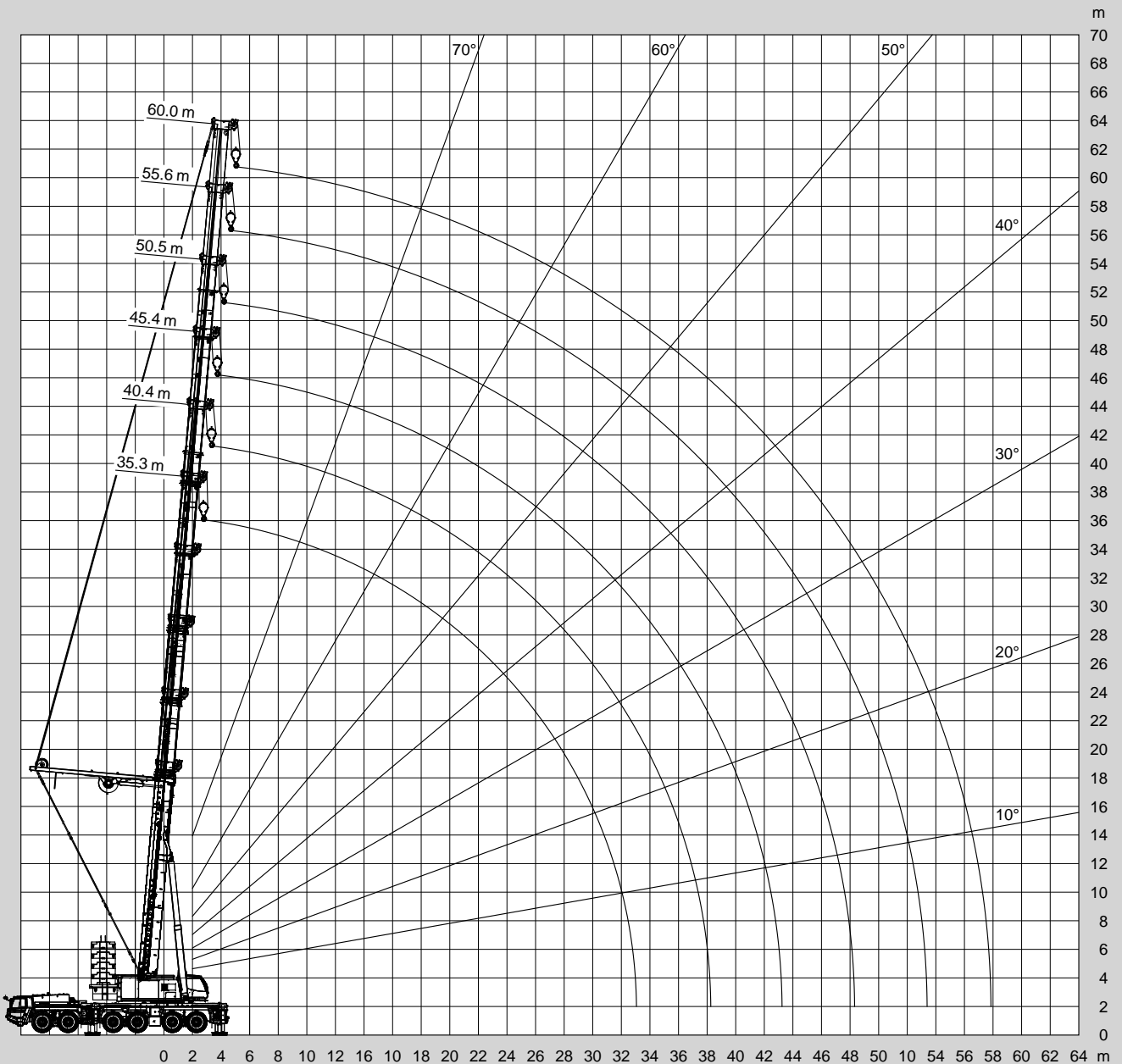

Tragfähigkeiten
Lifting capacities

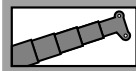

MB + LJ

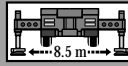

138t

DIN/ISO/EN

| | 15.0 m + 2.4 m + 20.3 m | | | 15.0 m + 2.4 m + 76.0 m | | | 45.4 m + 2.4 m + 76.0 m | | |
|------|-------------------------|------|------|-------------------------|------|-----|-------------------------|-----|-----|
| | 83° | 75° | 68° | 83° | 75° | 68° | 83° | 75° | 68° |
| 11.0 | 72.4 | | | | | | | | |
| 12.0 | 72.3 | | | | | | | | |
| 14.0 | 72.3 | | | | | | | | |
| 16.0 | 66.0 | 67.0 | | | | | | | |
| 18.0 | 59.1 | 60.9 | | | | | | | |
| 20.0 | 42.5 | 55.1 | 54.9 | | | | | | |
| 22.0 | | 50.2 | 50.1 | | | | | | |
| 24.0 | | | 46.0 | 10.6 | | | | | |
| 26.0 | | | | 10.5 | | | | | |
| 28.0 | | | | 10.5 | | | | | |
| 30.0 | | | | 10.4 | | | | | |
| 32.0 | | | | 10.3 | | | 4.0 | | |
| 34.0 | | | | 10.1 | | | 4.0 | | |
| 36.0 | | | | 10.0 | | | 4.0 | | |
| 38.0 | | | | 9.8 | 10.2 | | 4.0 | | |
| 40.0 | | | | 9.7 | 10.0 | | 4.0 | | |
| 42.0 | | | | 9.5 | 9.9 | | 4.0 | | |
| 44.0 | | | | 9.3 | 9.6 | | 4.0 | | |
| 46.0 | | | | 9.0 | 9.3 | | 4.0 | | |
| 48.0 | | | | 8.7 | 9.0 | 9.3 | 3.8 | | |
| 50.0 | | | | 8.4 | 8.7 | 9.0 | 3.8 | 3.0 | |
| 52.0 | | | | 7.8 | 8.2 | 8.4 | 3.8 | 3.0 | |
| 54.0 | | | | 7.3 | 7.6 | 7.9 | 3.8 | 3.0 | |
| 56.0 | | | | 6.9 | 7.2 | 7.4 | 3.8 | 2.8 | |
| 58.0 | | | | 6.5 | 6.7 | 6.9 | 3.8 | 2.8 | |
| 60.0 | | | | 6.1 | 6.3 | 6.5 | 3.8 | 2.8 | |
| 62.0 | | | | 5.5 | 5.9 | 6.1 | 3.8 | 2.8 | |
| 64.0 | | | | | | 5.8 | 3.8 | 2.8 | |
| 66.0 | | | | | | | 3.8 | 2.8 | 2.5 |
| 68.0 | | | | | | | 3.8 | 2.8 | 2.5 |
| 70.0 | | | | | | | 3.8 | 2.8 | 2.5 |
| 72.0 | | | | | | | 3.8 | 2.2 | 2.5 |
| 74.0 | | | | | | | 3.8 | 2.2 | 2.5 |
| 76.0 | | | | | | | 3.8 | 2.2 | 2.5 |
| 78.0 | | | | | | | 3.8 | 2.2 | 2.5 |
| 80.0 | | | | | | | 3.8 | 2.2 | 2.5 |
| 82.0 | | | | | | | 3.8 | 2.2 | 2.5 |
| 84.0 | | | | | | | | 2.2 | 2.3 |
| 86.0 | | | | | | | | 2.2 | 2.0 |
| 88.0 | | | | | | | | 2.2 | 1.9 |
| 90.0 | | | | | | | | 2.2 | 1.8 |
| 92.0 | | | | | | | | | 1.6 |
| 94.0 | | | | | | | | | 1.3 |

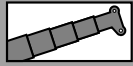

MB + LJ

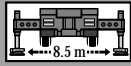

138t

DIN/ISO/EN

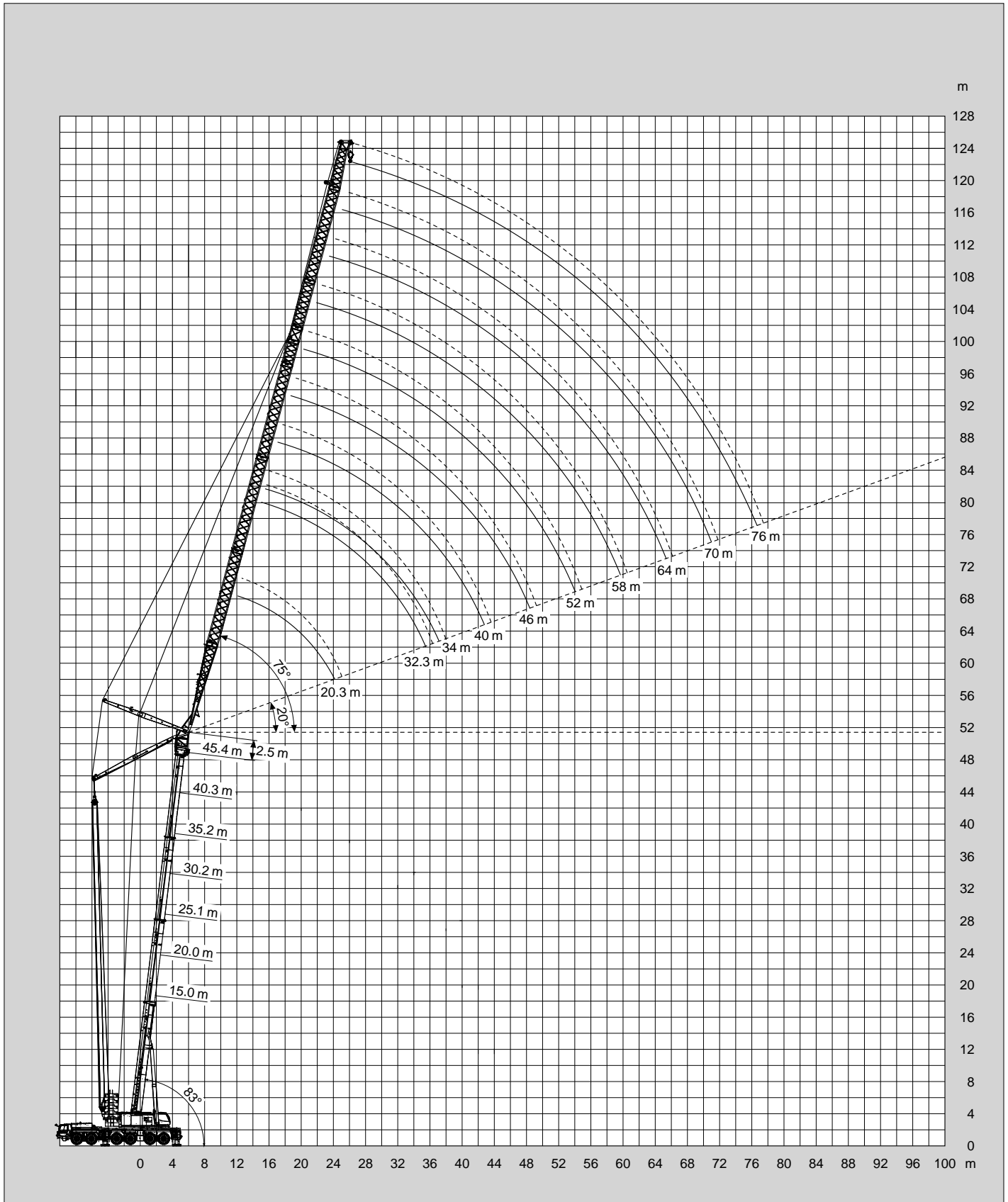

Anmerkungen zu den Traglasttabellen

Die Tragfähigkeiten im Festigkeitsbereich basieren auf DIN 15018 Blatt 2 und Blatt 3 und F.E.M.

Die Tragfähigkeiten im Standsicherheitsbereich entsprechen DIN 15019 Teil 2 / ISO 4305 / EN 13000.

Die Tragfähigkeiten sind in metrischen Tonnen angegeben.

Das Gewicht des Lasthakens bzw. der Hakenflasche und weiterer Anschlagmittel ist von der Tragfähigkeit abzuziehen.

Die Tragfähigkeiten für den Teleskopausleger gelten nur bei demonstrierter Spitze.

Die Ausladung ist der horizontale Abstand von Mitte Drehkranz bis Mitte freihängender, nicht schwingender Last.

Tragfähigkeitsänderungen vorbehalten.

Obige Angaben dienen nur zur Information. Die Bedienungsanleitungen müssen zu Rate gezogen werden, bevor die Maschine in Betrieb genommen wird. Alle hier gemachten Angaben beziehen sich auf die Standard-Ausführung. Jegliche Ausrüstungsveränderungen können die angegebenen Werte beeinflussen.

Remarks relating to the rating charts

The lifting capacities in the structural area are based on DIN 15018 parts 2 and 3 and F.E.M.

The lifting capacities in the stability area are based on DIN 15019 part 2 / ISO 4305 / EN 13000.

The lifting capacities are shown in metric tons.

The weight of load handling devices such as hook blocks, slings, etc., must be considered as part of the load and must be deducted from the lifting capacities.

The lifting capacities for the telescopic boom apply to a crane with no boom extensions being stowed or mounted on the crane.

The working radius is the horizontal distance from the centre of rotation to the centre of the freely suspended non-oscillating load.

The lifting capacities are subject to change without prior notice.

The above remarks are for basic information only and the operator's manual must be consulted before operating this crane. All data and performances refer to the standard crane. The addition of optional and other equipment may affect the performance of the crane.

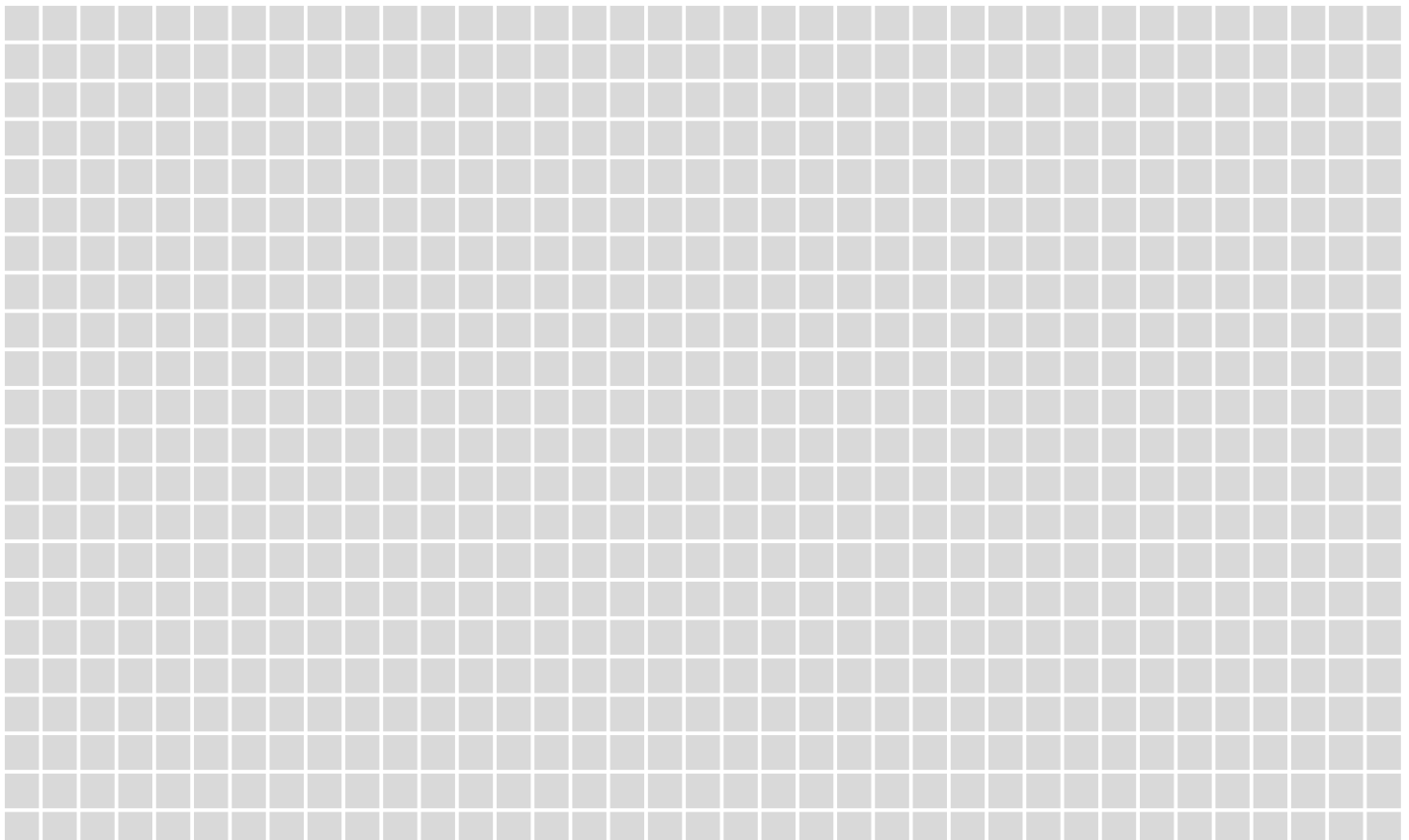

Gegengewichtvarianten
Counterweight versions

| Gesamtgewicht Total weight | Gegengewicht / Counterweight | | | | | |
|-------------------------------|------------------------------|----------|------------|-----------|-----------|-----------|
| | 7.5 t ① | 9 t ② | 8.5 t ③ | 11 t ④ | 11 t ⑤ | 10 t ⑥ |
| 138 t | 1 | 1 | 1 | 2 | 1 | 8 |
| 118 t | 1 | 1 | 1 | 2 | 1 | 6 |
| 98 t | 1 | 1 | 1 | 2 | 1 | 4 |
| 78 t | 1 | 1 | 1 | 2 | 1 | 2 |
| 58 t | 1 | 1 | 1 | 2 | 1 | |
| 47 t | 1 | 1 | 1 | 2 | | |
| 25 t | 1 | 1 | 1 | | | |
| 16.5 t | 1 | 1 | | | | |
| 7.5 t | 1 | | | | | |

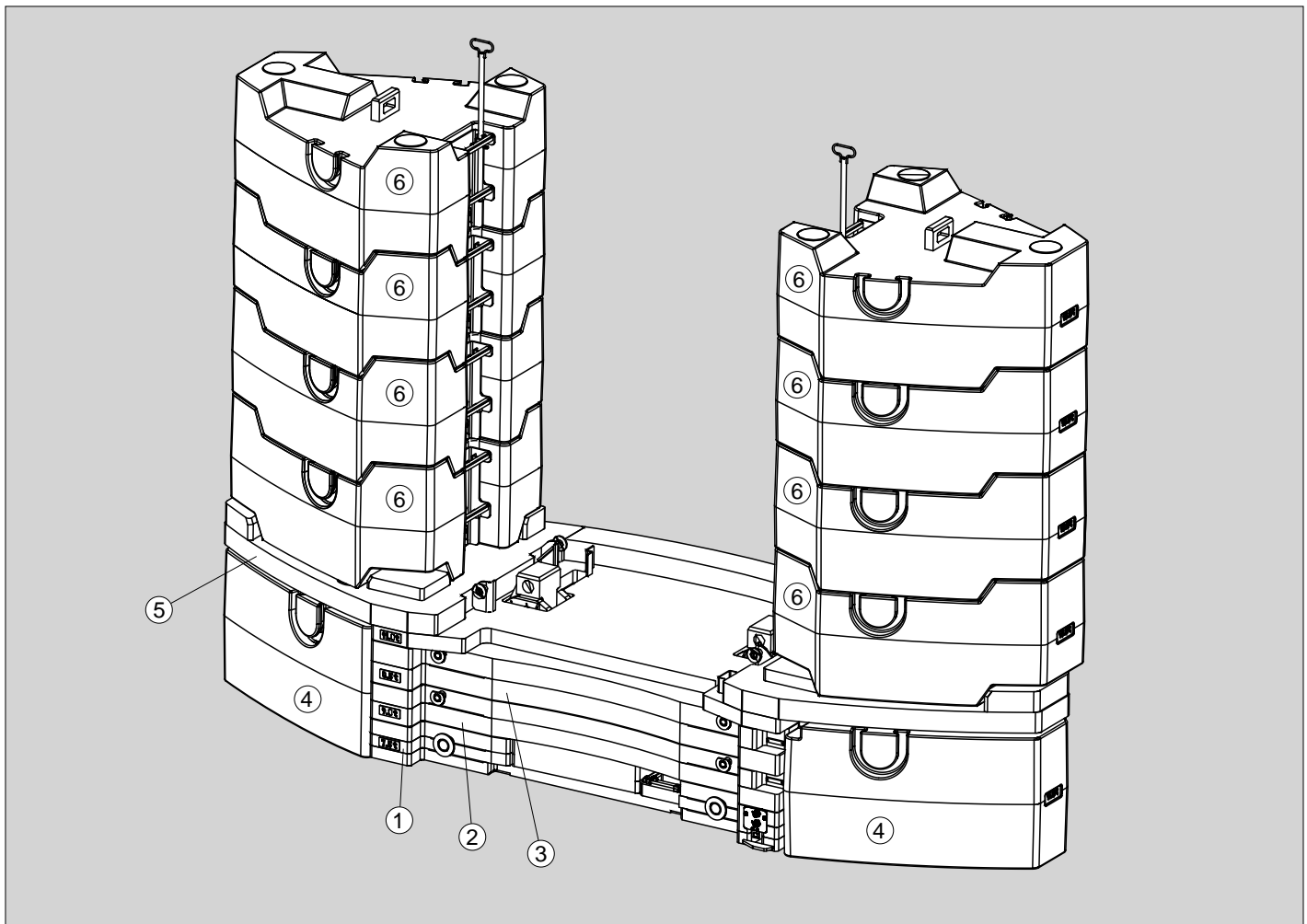
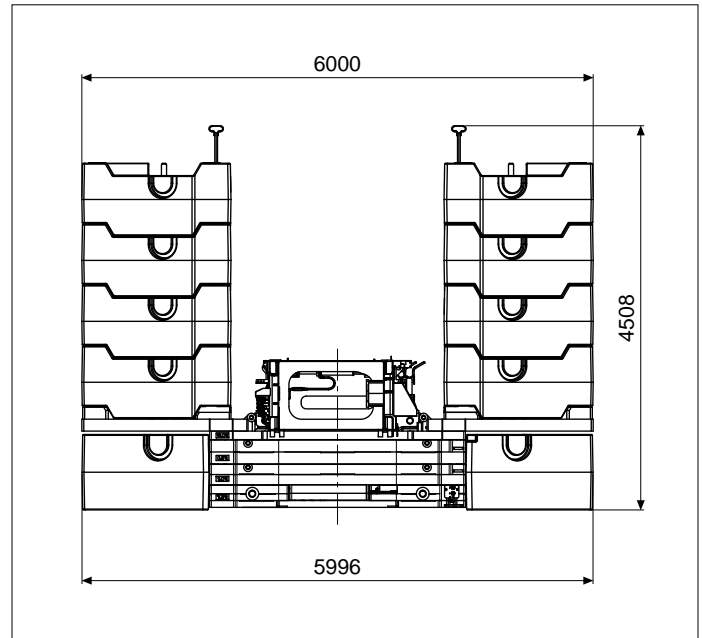

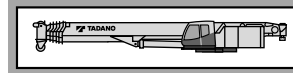
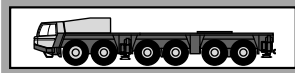

Rahmen Verwindungs- und biegesteife Schweißkonstruktion aus hochfestem Feinkornstahl. Zentralschmieranlage.

Abstützung 4-Punkt-Abstützung, hydraulisch, Bedienungsmöglichkeiten an beiden Seiten des Fahrgestelles und in der Oberwagenkabine.
Abstützbasis 8,5 m (und 8,0 m, 6,8 m, 5,5 m) x 8,9 m.

Motor Mercedes-Benz 8-Zylinder-Dieselmotor OM 502 LA (Euromot III B), wassergekühlt, Leistung 480 kW (653 PS) bei 1800 min⁻¹. Drehmoment 3000 Nm (275 kpm) bei 1300 min⁻¹. Motorleistung nach 80/1269/EWG. Kraftstoffbehälter 450 l. AdBlue-Behälter 40 l.

Getriebe ZF-TC-Tronic 12 TC 3040 SO mechanisches Schaltgetriebe mit Wandlerschaltkupplung und integriertem Intarder, elektronisch-pneumatisch betätigter Trockenkupplung und vollautomatischer Schaltung mit 12 Vorwärts- und 2 Rückwärtsgängen.

Verteilergetriebe

Antrieb 12 x 8

Achsen

1. Achse: gelenkt, angetrieben, Differentialsperre quer.
2. Achse: gelenkt, nicht angetrieben.
3. Achse: gelenkt, angetrieben, Differentialsperre längs und quer.
4. Achse: gelenkt, angetrieben, Differentialsperre quer.
5. Achse: gelenkt, angetrieben, Differentialsperre quer.
6. Achse: gelenkt, nicht angetrieben.

Achsaufhängung Hydropneumatische Federung mit Niveauregulierung.

Bremsen Druckluft-Zweikreis-Scheibenbremsanlage. Feststellbremse als Federspeicherbremse an der 3., 4., 5. und 6. Achse wirkend. Intarder mit Bremsomat-Funktion und Konstantdrosselanlage mit Auspuffklappenbremse als Dauerbremse.

Räder 12-fach 445/95 R 25 (16.00 R 25).

Lenkung ZF-Servocom-Zweikreishydraulenlenkung mit Notlenkpumpe. Mechanische Lenkung der 1. und 2. Achse. Im Betriebsmodus "Straße" werden die Achsen 3-6 bis zu einer Geschwindigkeit von 30 km/h elektronisch mitgelenkt. Ab einer Geschwindigkeit von 30 km/h werden die Achsen 4 und 5 in in Geradeausposition verriegelt und ab einer Geschwindigkeit von 50 km/h zusätzlich die Achsen 3 und 6.

Unterswagenkabine Zwei-Mann-Frontfahrerhaus in Stahl-Kunststoff-Verbund-Konstruktion, Sicherheitsverglasung, luftgefederte Sitze (Fahrersitz mit Heizung) und motorabhängige Warmwasserheizung, Radio-CD-Player, Kontroll- und Bedienungselemente für den Fahrbetrieb, Tempomat- / Bremsomat-Funktion.

Elektrische Anlage 24 Volt-Gleichstrom, 2 Batterien, Verdrahtung mit CAN-Bus-Komponenten, integrierte Eigendiagnose Faun-CSS-System, Abstützbeleuchtung. Die elektrische Anlage entspricht der EG-Norm.

Zusatzrüstung (gegen Mehrpreis)
Anhängerkupplung, motorunabhängige Zusatzheizung mit Motorvorwärmung, Klimaanlage, ABS, 525/80 R 25 (20.5 R 25) Bereifung, Reserverad,
Sonderlackierung und Beschriftung

Rahmen Verwindungssteife Schweißkonstruktion mit einer außenverzahnten, dreireihigen Rollendrehverbindung, um 360° unbegrenzt drehbar.

Motor Mercedes-Benz 6-Zylinder-Dieselmotor OM 926 LA (Euromot III B), wassergekühlt. Drehzahl ist über Fußpedal stufenlos regelbar, Leistung 195 kW (265 PS) bei 2200 min⁻¹. Drehmoment 1100 Nm bei 1200 - 1600 min⁻¹, Motorleistung nach DIN 6270B/DIN 6271. Kraftstoffbehälter 230 l. AdBlue-Behälter: 8 l.

Hydraulik System Diesel-hydraulisch mit 3-Kreishydraulik, 1 leistungsgeregelte Axialkolben-Doppelpumpe (hydraulisch verstellbar), 1 Axialkolbenpumpe und 1 Zahnradpumpe, Ölkühler.

Steuerung Zwei 4-fach Kreuzsteuerhebel mit elektrischer Vorsteuerung.

Teleskopausleger Fünfteiliger Teleskopausleger aus hochfestem Feinkornstahl, bestehend aus einem Grundausleger und 4 Teleskopteilen, 1 Teleskopzylinder, hydraulisch unter Teillast teleskopierbar. 15,0 m - 60,0 m lang.

Wippwerk Ein Differentialzylinder mit angebautem Senkbremssperrventil.

Hubwerk Axialkolben-Verstell-Motor, Hubwerkstrommel mit eingebautem Planetengetriebe und federbelasteter Hydro-Lamellenbremse mit integriertem Freilauf beim Heben. Hubseil mit 'Super-Stop' Einrichtung.

Drehwerk Axialkolben-Motor, dreistufiges Planetengetriebe mit automatischer Betriebs- und Feststellbremse, offener Hydraulikkreislauf mit Drehwerk-Freischaltung. Drehgeschwindigkeit stufenlos von 0 - 1,1 min⁻¹.

Gegengewicht Gesamtgewicht 138 t teilbar. Die Bedienung erfolgt mittels einer Fernbedieneinheit.

Oberwagenkabine Großräumige Krankabine in Stahl-Kunststoffausführung mit Sicherheitsverglasung und getönten Scheiben, kippbarem Arbeitsplatz mit verstellbarem, hydraulisch gedämpftem Fahrersitz mit Heizung, motorabhängige und motorunabhängige Warmwasserheizung (mit Motorvorwärmung), Radio-CD-Player, Kontroll- und Bedienungselemente sowie graphische LCD-Anzeige für Kranbetrieb.

Elektrische Anlage 24 Volt-Gleichstrom, 2 Batterien.

Sicherheitseinrichtungen 'Lift- und 'Release Adjuster', Lastmomentbegrenzung (LMB), Windmesser, Arbeitsbereichsbegrenzung, Hubendschalter, Windend-schalter, Seilwindendrehmelder, Sicherheitsventile gegen Rohr- und Schlauchbrüche. Sperrventile an Hydraulik-Zylindern.

Zusatzrüstung (gegen Mehrpreis)
Power-System PS, verschiedene Auslegerverlängerungen, Unterflaschen von 12,5 t bis 250 t, Klimaanlage, 2. Hubwerk, Sonderlackierung und Beschriftung.

Weitere Zusatzrüstung auf Anfrage.

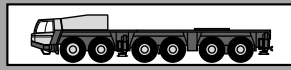

Frame Torsion resistant, welded construction made from high strength, fine-grained steel. Central lubricating system.

Outriggers 4 point, double telescopic hydraulic outriggers with controls on both sides of carrier and in superstructure cab. Outrigger base 8.5 m (8.0 m, 6.8 m, 5.5 m mid extension) x 8.9 m.

Carrier engine Mercedes-Benz 8 cylinder model OM 502 LA (Euromot III B), water-cooled diesel engine. Rated at 480 kW (653 HP) at 1800 min⁻¹. Torque 3000 Nm (275 kpm) at 1300 min⁻¹. Engine rating according to 80/1269/EWG. Fuel tank 450 l. AdBlue-tank 40 l.

Transmission ZF-TC-Tronic 12 TC 3040 SO mechanical transmission with torque converter control clutch and integrated intarder, electro-pneumatically operated dry-type clutch and automatic gear shifting with 12 forward gears and 2 reverse gears.

Transfer Case

Drive 12 x 8

Axles

1st axle: steered, driven.
2nd axle: steered, not driven.
3rd axle: steered, driven, with longitudinal differential lock.
4th axle: steered, driven.
5th axle: steered, driven.
6th axle: steered, not driven.
All driven axles with transverse differential locks.

Suspension Hydro-pneumatic with levelling adjustment.

Brake system Service disc brakes: dual circuit compressed air system. Parking brake: spring loaded type acting on 3rd, 4th, 5th and 6th axles. Auxiliary brakes: intarder with brake control, engine exhaust brake and constant throttle engine brake system.

Tyres (12) 445/95 R 25 (16.00 R 25).

Steering system ZF-Servocom, dual circuit hydraulic steering with emergency steering pump, mechanical hydraulically-assisted steering of front two axles. On road modethe 1st and 2nd axle are permanently steered and mechanically connected to the steering gear unit and the 3rd, 4th, 5th and 6th axle are automatically steered, electro-hydraulically, with the 1st and 2nd axles up to a travel speed of 30 km/h and 50 km/h respectively. At a speed of 30 km/h, the 4th and 5th axles are automatically locked in the straight ahead position. At a speed of 50 km/h, the 3rd and 6th axle is automatically locked in the straight ahead position.

Carrier cab Two man full width cab of composite (steel sheet metal and fibre-glass) structure, with safety glass, air-cushioned adjustable seats (driver seat with heater) and engine dependent hot-water heater, radio- CD-player, complete controls and instrumentation for road travel. Speed and brake control.

Electrical system 24 volt DC system, 2 batteries, CAN-Bus system with Faun CSS integrated self-diagnosis system, outrigger lighting. Electrical system conforms with EEC regulations.

Optional Equipment (at extra charge)

Towing attachment, engine independent additional heater with engine pre-heat, air conditioning, ABS, 525/80 R 25 (20.5 R 25) tyres, spare wheel and tyre, special painting and lettering.

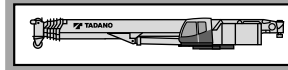

Frame Torsion-resistant, all-welded structure of high strength steel. Connected to carrier by triple roller bearing slewing ring with external gearing for 360° continuous rotation.

Superstructure engine Mercedes-Benz 6 cylinder model OM 926 LA (Euromot III B), water cooled, diesel engine. PRM infinitely variable via foot pedal, rating 195 kW (265 HP) at 2200 min⁻¹. Torque 1100 Nm (112 kpm) at 1200 - 1600 min⁻¹. Engine rating according to DIN 6270B / DIN 6271. Fuel tank 230 l. AdBlue-tank 8 l

Hydraulic system Three circuit diesel hydraulic system with 1 power controlled axial piston double pump (hydraulically adjustable) 1 axial piston pump and 1 gear pump, oil cooler.

Controls Electrical, 2 joy-stick levers for simultaneous operation of crane motions.

Telescopic boom 5 sections, made of high tensile, fine-grained steel, consisting of 1 base section and 4 telescoping sections extended by means of a single telescopic cylinder. All telescope sections extendable under partial load. 15.0 m to 60.0 m long.

Derricking system 1 double acting hydraulic cylinder with integral brake and holding valve.

Main winch Axial piston variable displacement motor, winch drum with integrated planetary reduction and with hydraulically controlled spring-loaded, multiple disc brake. Hoist cable with 'Super-Stop' easy reeving system.

Slewing system Axial piston motor with three-stage planetary gear with automatic service and a parking brake. Open hydraulic circuit with free slewing function. Speed infinitely variable 0 - 1.1 min⁻¹.

Counterweight Total 138 t divisible, assembled and disassembled by hydraulic cylinders operated by remote control.

Superstructure cab Spacious panoramic cab of composite structure with safety (tinted) glass windows, tiltable cockpit with hydraulically cushioned adjustable seat with heater, one engine dependent hot-water heater and one engine independent hot-water heater (with engine pre-heat), radio-CD-player. Complete controls and instrumentation plus LCD graphic display for crane operation.

Electrical system 24 volt DC system, 2 batteries.

Safety devices 'Lift- and Release Adjuster', load moment device (LMD), anemometer, working area limiter, hoist limit switch, lower limit switch and drum turn indicator, safety valves against pipe and hose rupture, holding valves on hydraulic cylinders.

Optional Equipment (at extra charge)

Power-System PS, several boom extensions, Hook blocks 12.5 t - 250 t, air conditioning, auxiliary winch, special painting and lettering.

Further optional equipment available upon request.

Worldwide offices

International

TADANO Ltd.

International Division
4-12, Kamezawa 2-chome
Sumida-Ku, Tokyo 130-0014, Japan
Phone: +81-3-3621-7750
Fax: +81-3-3621-7785
E-mail: tdnihq@tadano.co.jp

TADANO America Corporation

4242 West Greens Road
Houston, TX 77066, USA
Phone: +1-281-869-0030
Fax: +1-281-869-0040
E-mail: sales@tadano-cranes.com

TADANO MANTIS Corporation

1705 Columbia Avenue, Suite 200
Franklin, Tennessee USA 37065
Phone: +1-800-272-3325
Fax: +1-615-790-6803
E-mail: sales@mantisranes.com

TADANO Ltd. Middle East Representative Office

P.O.Box 18302, LOB15-323
Jebel Ali Free Zone, Dubai, UAE
Phone: +971-4-887-1353
Fax: +971-4-887-1703
E-mail: tadano@tadano.ae

TADANO Oceania Pty Ltd.

4/12 Archimedes Street Darra
Queensland 4076
Australia
Phone: +61-7-3120-8750
Fax: +61-7-3120-8760
E-mail: pshelton@tadano.com.au

TADANO Ltd. Beijing Office

Jing Guang Centre, Room 2905
Hu Jia Lou, Chao Yang Qu
Beijing, China
Phone: +86-10-6597-3210
Fax: +86-10-6597-3220
E-mail: beijing@tadano.co.jp

TADANO South China Co. Ltd.

Room 1803, 18/F Seaview Commercial
Building 21-24 Connaught Road West
Hong Kong
Phone: +852-2544-9310
Fax: +852-2541-5828
E-mail: info@tadanosc.com

TADANO Korea Co. Ltd.

Dangok Bldg 2F, #642-7, Bokjeong-dong
Sujeong-gu, Seongnam-si, Gyeonggi-do
461-830, Korea
Phone: +82-2-714-1600
Fax: +82-2-3274-1304
E-mail: tadano@korea.com

TADANO Asia Pte Ltd.

11 Tuas View Crescent
Multico Building
Singapore 637643
Phone: +65-6863-6901
Fax: +65-6863-6902
E-mail: Tdn-crane@tadanoasia.com

Taiwan TADANO Ltd.

16F, No. 39, Sec. 2 Twng-Hwa S. Rd.
Taipei
Taiwan
Phone: +886-2-2754-0252
Fax: +886-2-2709-2086
E-mail: tadano@ms18.hinet.net

Europe

TADANO FAUN GmbH

Faunberg 2
91207 Lauf a. d. Pegnitz
Germany
Phone: +49-9123-955-0
Fax: +49-9123-3085
E-mail: info@tadanofaun.de

Detaillierte Informationen über unsere Internationalen Händler und Service Niederlassungen finden Sie im Internet.
For detailed information about our International Distributor and Service Network, please refer to our homepages.
www.tadano.co.jp + www.tadanoamerica.com + www.mantisranes.com + www.tadanofaun.de

Herausgeber / Publisher:

TADANO FAUN GmbH
P.O.Box 10 02 64
91205 Lauf
Germany

